

# Technical Data - X22 - Semi-automatic tool change

Power: 1,5 kW | 2,2 kW

Voltage: 230 V | 400 V

Number of poles: 2-pole | 4-pole

Cooling method: Air cooling

Tool interface: QTC HSK-C32

Rotational speed: 25.000 - 45.000 rpm

Spindle bearings: Steel bearings | Hybrid bearings

Temperature sensor: PTC | PT100 (bearings, coil end)

Rotational speed sensor: Incremental | Inductive

Motor plug: 9-pole straight | 9-pole angled

Sensor plug: 17-pole straight | 17-pole angled

Coolant connection: 8 mm straight | 8 mm angled

Fan: 24 V

Protection class: IP30

Weight: 4,9 kg

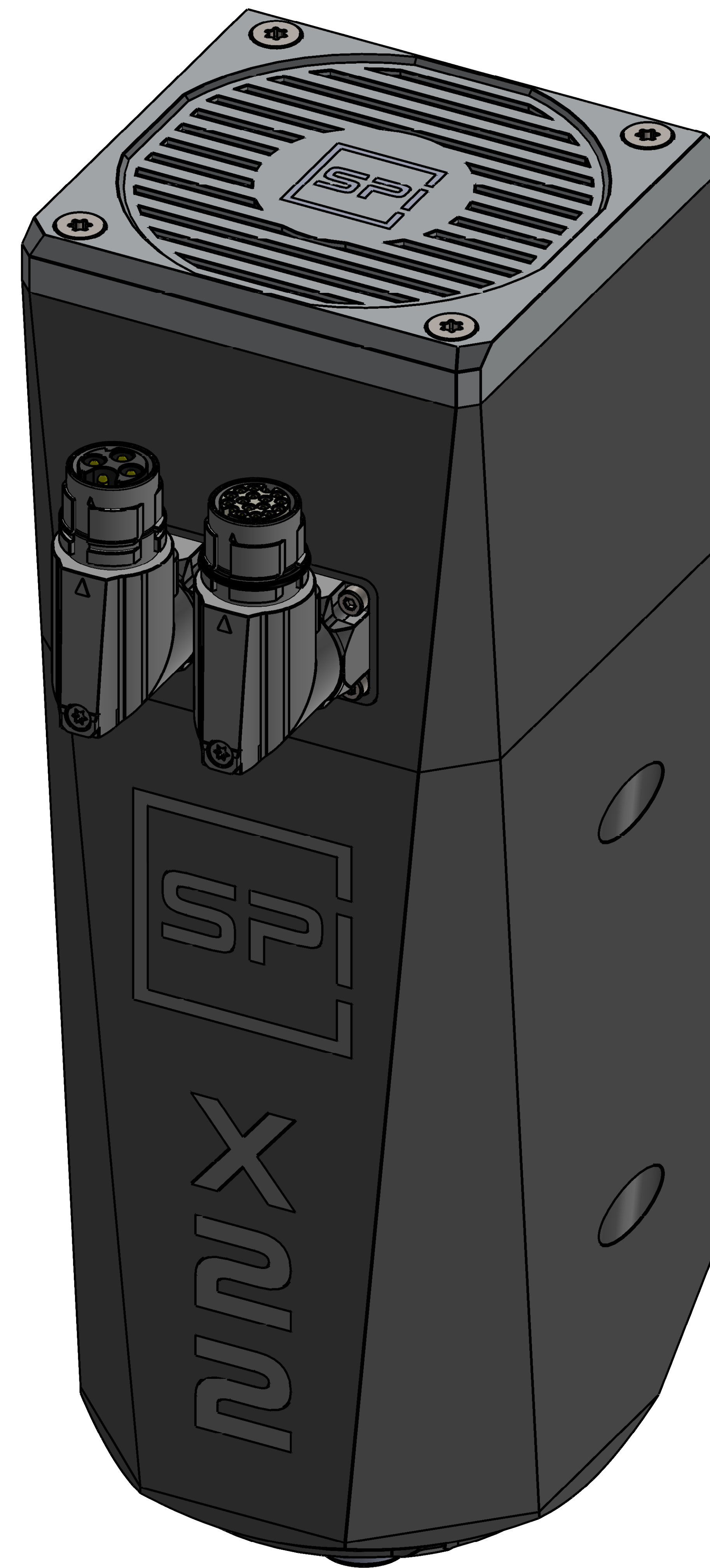

Full equipment  
(Sensor plug required from the second sensor on)



Basic configuration

Title  
X22-L-QTC-HSK32

Item-Nr.  
XP024



Scale	Rev.	Date	Sheet
2:1	A	22.02.2022	2